



Unflanged Guard Assembly Guide

1. Locate holes no less than 1/4" away from the edge of the backplate Tab.

Dimension "A" should be 7/16" for a 10-24 u-nut or 3/4" for a 1/4-20 u-nut.

Drill Clearance holes for machine screws.

3/16" for 10-24
5/16" for 1/4-20

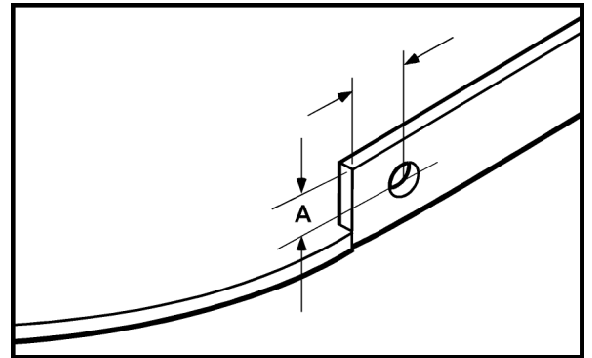

2. Make a reference mark on the edge of the backplate where the tab bends up.

Measure the distance from the back of the backplate to the center of the hole. This is needed to locate the corresponding mounting holes on the guard.

Slide the u-nut over the hole.

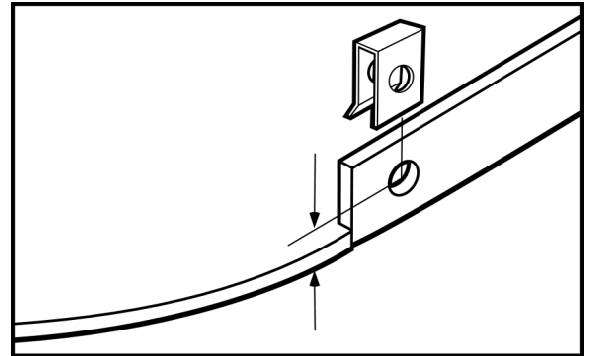

3. Place the backplate in the guard with tabs inward.

Using the marks and measurements from the previous steps, locate the screw holes for the guard.

Remove the backplate and drill the guard mounting holes using the same bit as in step one.

4. Locate and drill holes for shafts as needed.

